

MULTIFUNCTIONAL SCALES WPW



release date 15-03-2012



Multifunctional WPW scales are manufactured in standard version dedicated to general use, and in upgraded versions as:

- Counting scales **WPW/L** series
- Labeling scales **WPW/E** series
- Dosing scales **WPW/D** series
- Formula making scales **WPW/R** series

All types of scales are available with the same capacities, and they differ in functionality. Upgraded scale versions provide the functionality of a standard scale and dedicated option.

WPW multifunctional scales are available in two variants:

- Multifunctional single range scales (e.g. WPW 6 C1/K);
- Multifunctional dual range scales (e.g. WPW 3/6 C1/K).

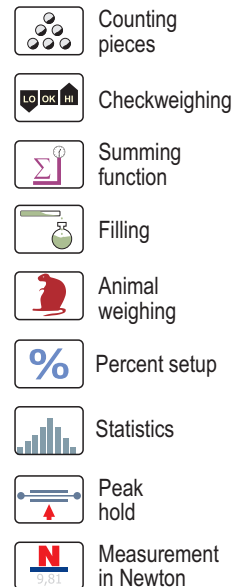

Standard WPW scale:

Multifunctional WPW scale features a terminal PUE C41H with backlit LCD display and a single load cell mild steel and powder coated weighing platform. The standard WPW scale is available with maximum capacities from **6 kg to 300 kg**, and corresponding readability from **2g to 100 g**. The weighing platforms dedicated to the WPW series are models from **C1 (290×360mm) to C3 (500×700mm)**.

The terminal PUE C41H used in the WPW multifunctional scale enables cooperating with computer software "WPW EDITOR" and "LABEL EDITOR". The computer software communicates with the PUE C41H terminal through its interfaces: RS 232, RS 485 (baud rate from 2400 to 115200 bit/s) and ETHERNET.

Functionality:

- Cooperation with a single weighing platform
- Other measuring units [kg, lb, oz, ct, N, g]
- Definable access level
- Current updating of statistical data
- Saving up to 60 000 weighing records
- Filtering weighing results and reports from weighing
- Optional configuration of diodes operating mode
- Creating optional texts for printouts
- Implementing printout templates from weighing and reports
- Database of tares
- Manual or automatic tare
- Automatic scale shutdown

Scale enables cooperation with:

- WPW EDITOR computer software
- Receipt and label printers
- LABEL EDITOR computer software
- External PRINT-TARA-ZERO button
- Control panel: 3inputs / 3outputs
- Barcode scanner
- Transponder card scanner
- Additional modules (as additional equipment of PUE C41H):
 - analog module AN series
 - additional relays module
 - IN/OUT additional module
 - RS485 module
 - ETHERNET module

Counting scale WPW/L:

WPW/L scales are applied for counting details with equal unit mass, and connected to label printers, they enable printing labels for matching weighed goods. Extending system's functionality by the additional weighing module (optional) enables cooperating with an additional weighing platform. Such configuration allows for determining unit mass with maximal expected readability.

Additional functionality:

- parts counting mode
- basic weighing unit [psc]
- other weighing units [kg, lb, oz, ct, N, g]
- cooperation with additional platform

Labeling scale WPW/E:

WPW/E scales are applied for weighing applications featuring a label printer. The system is dedicated for labeling weighed goods, for instance in packaging process.

The software implemented in the PUE C41H terminal allows for generating:

- standard labels for matching single goods,
- cumulative (c) labels on completion of package weighing
- cumulative of cumulative (cc) labels on completion of batch weighing.

Dedicated Citizen label printers, available as additional equipment, increase system functionality.

Software functionality in labeling scales:

- Three modes of printing c and cc labels on labeling scales:
 - manually,
 - by label counter,
 - by set value of product mass;
- Setting the scale as a control scale (+/- weighing result control);
- Identification of products by barcodes EAN-13 and EAN-128;
- Databases of operators, products, materials, clients, weighing records, universal variables, tares.

Dosing scale WPW/D:

WPW/D scales as standard feature BARCHER/FORMULATION software combined with external automation systems, which consist of control and executive components. Such devices give option of automatic, semi-automatic or manual dosing of loose substances and liquids. Additionally, the software enables planning and preparing mixtures from formulation components (dosing output). The components have their nominal mass assigned, and they are batched by the scale in dosing process.

Functionality of software BATCHER:

- three dosing modes: manual operation, automatic operation and dosing on "-",
- setting time delay on switching between dosing thresholds,
- declaring time delay of process completion,
- setting OUTPUTS operation (one of three available modes) of user's dosing instruments,
- ceasing and/or aborting dosing process at optional moment,
- cooperation with external function keys TARE, ZERO, PRINT, START, STOP, HOLD, CHUTE, CHUTE START and optional configuration on inputs numbers assigned to a key,
- optional configuration of outputs numbers for functions: MIN, OK, MAX, STABLE, THRESHOLD 1, THRESHOLD 2, CHUTE,
- printing reports from weighing – report filtering by: start date, end date, operator code, product code, weighing type, weighing platform no., batch no.,
- databases of: operators, products, weighing records, universal variables, tares.

Formula making scale WPW/R:

Formula making scales WPW/R feature BARCHER/FORMULATION software combined with external automation systems, which consist of control and executive components. Such devices give option of automatic, semi-automatic or manual dosing of loose substances and liquids. Additionally, the software enables planning and preparing mixtures from formulation components (dosing output). The components have their nominal mass assigned, and they are batched by the scale in dosing process.

Functionality of software BATCHER / FORMULATION:

- rescaling mass of formula ingredients (multiplier of formula mass);
- setting tare mode of each ingredient during dosing or formula making process;
- setting the means of ingredient's mass acceptance after weighing (manual or automatic);
- declaring number of cycles for specific formula;
- hold and/or stop of formula or dosing process at optional stage of advancement;
- cooperation with external buttons: TARE, ZERO, PRINT, START, STOP, (START/STOP) CHUTE and random configuration of inputs assigned to the button;
- Free configuration of output numbers for the following functions; MIN, OK..., MAX, STABLE, CHUTE P1, CHUTE P2, WORK;
- Printing reports from dosing and formula making process;
- Databases of: operators, products, weighing records, universal variables, tares.

The software for WPW formula making scale features a default printout template for formulations, containing parameter on: report date and time, operator name, formulation name, formulation code, formulation mass, product name, product code, product mass, product settings, product deviation.

Technical data:

	WPW 6 C1/K	WPW 15 C1/K	WPW 30 C1/K	WPW 30 C2/K	WPW 60 C2/K
	WPW/L 6 C1/K	WPW/L 15 C1/K	WPW/L 30 C1/K	WPW/L 30 C2/K	WPW/L 60 C2/K
	WPW/E 6 C1/K	WPW/E 15 C1/K	WPW/E 30 C1/K	WPW/E 30 C2/K	WPW/E 60 C2/K
	WPW/D 6 C1/K	WPW/D 15 C1/K	WPW/D 30 C1/K	WPW/D 30 C2/K	WPW/D 60 C2/K
	WPW/R 6 C1/K	WPW/R 15 C1/K	WPW/R 30 C1/K	WPW/R 30 C2/K	WPW/R 60 C2/K
Max capacity	6 kg	15 kg	30 kg	30 kg	60 kg
Readability	2 g	5 g	10 g	10 g	20 g
Tare range	-6 kg	-15 kg	-30 kg	-30 kg	-60 kg
Pan size	290×350 mm			400×500 mm	
Working temperature	-10° ± +40 °C				
Output signal	RS 232, RS 485				
IP rating	IP 65 - construction, IP 66/67 - indicator				
Power supply	230V AC 50Hz, rechargeable battery 6V 3Ah				
Display	LCD (backlit)				
Net weight / Gross weight	9,7 / 11 kg			18,7 / 21 kg	
Packaging dimensions	550×420×220 mm			720×580×220 mm	

Technical data:

	WPW 150 C2/K	WPW 300 C2/K	WPW 150 C3/K	WPW 300 C3/K
	WPW/L 150 C2/K	WPW/L 300 C2/K	WPW/L 150 C3/K	WPW/L 300 C3/K
	WPW/E 150 C2/K	WPW/E 300 C2/K	WPW/E 150 C3/K	WPW/E 300 C3/K
	WPW/D 150 C2/K	WPW/D 300 C2/K	WPW/D 150 C3/K	WPW/D 300 C3/K
	WPW/R 150 C2/K	WPW/R 300 C2/K	WPW/R 150 C3/K	WPW/R 300 C3/K
Max capacity	150 kg	300 kg	150 kg	300 kg
Readability	50 g	100 g	50 g	100 g
Tare range	-150 kg	-300 kg	-150 kg	-300 kg
Pan size	400×500 mm		500×700 mm	
Working temperature	-10° ± +40 °C			
Output signal	RS 232, RS 485			
IP rating	IP 65 - construction, IP 66/67 - indicator			
Power supply	230V AC 50Hz, rechargeable battery 6V 3Ah			
Display	LCD (backlit)			
Net weight / Gross weight	18,7/21 kg		23,7/30 kg	
Packaging dimensions	720×580×220 mm		820×640×260 mm	

MULTIFUNCTIONAL DUALRANGE SCALES WPW**Technical data:**

	WPW 3/6 C1/K	WPW 6/15 C1/K	WPW 15/30 C1/K
	WPW/L 3/6 C1/K	WPW/L 6/15 C1/K	WPW/L 15/30 C1/K
	WPW/E 3/6 C1/K	WPW/E 6/15 C1/K	WPW/E 15/30 C1/K
	WPW/D 3/6 C1/K	WPW/D 6/15 C1/K	WPW/D 15/30 C1/K
	WPW/R 3/6 C1/K	WPW/R 6/15 C1/K	WPW/R 15/30 C1/K
Max capacity	3/6 kg	6/15 kg	15/30 kg
Readability	1/2 g	2/5 g	5/10 g
Tare range	-6 kg	-15 kg	-30 kg
Pan size	290×350 mm		
Working temperature	-10° ± +40 °C		
Output signal	RS 232, RS 485		
IP rating	IP 65 - construction, IP 66/67 - indicator		
Power supply	230V AC 50Hz, rechargeable battery 6V 3Ah		
Display	LCD (backlit)		
Net weight / Gross weight	9,7/11 kg		
Packaging dimensions	550×420×220 mm		

Technical data:

	WPW 15/30 C2/K	WPW 30/60 C2/K	WPW 60/150 C2/K	WPW 150/300 C2/K
	WPW/L 15/30 C2/K	WPW/L 30/60 C2/K	WPW/L 60/150 C2/K	WPW/L 150/300 C2/K
	WPW/E 15/30 C2/K	WPW/E 30/60 C2/K	WPW/E 60/150 C2/K	WPW/L 150/300 C2/K
	WPW/D 15/30 C2/K	WPW/D 30/60 C2/K	WPW/D 60/150 C2/K	WPW/L 150/300 C2/K
	WPW/R 15/30 C2/K	WPW/R 30/60 C2/K	WPW/R 60/150 C2/K	WPW/L 150/300 C2/K
Max capacity	15/30 kg	30/60 kg	60/150 kg	150/300 kg
Readability	5/10 g	10/20 g	20/50 g	50/100 g
Tare range	-30 kg	-60 kg	-150 kg	-300 kg
Pan size	400×500 mm			
Working temperature	-10° ÷ +40 °C			
Output signal	RS 232, RS 485			
IP rating	IP 65 - construction, IP 66/67 - indicator			
Power supply	230V AC 50Hz, rechargeable battery 6V 3Ah			
Display	LCD (backlit)			
Net weight / Gross weight	18,7/21 kg			
Packaging dimensions	720×580×220 mm			

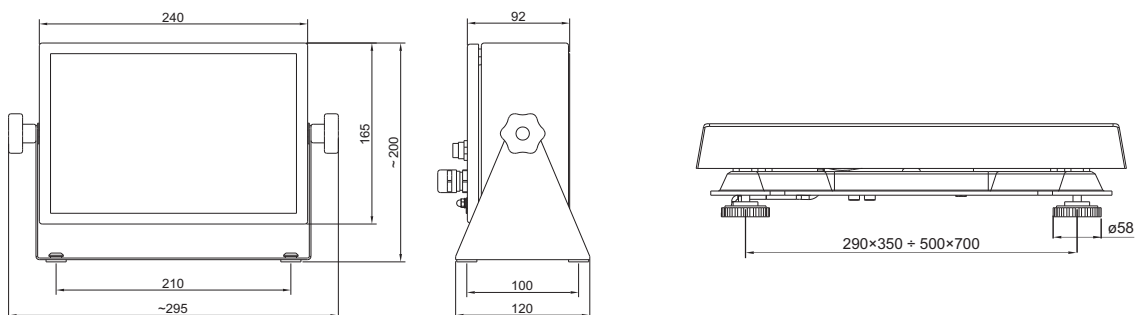

Accessories:

Antivibration table for industrial scales	Module WE8
"Kafka" thermal printer	Cable RS 232 [scale - Kafka printer]: Pt0018
"Epson" dot matrix printer	Cable RS 232 [scale - printer "Epson"]: PT0019
"Citizen" label printer	Cable RS 232 [scale - printer "Citizen"]: PT0019
External tare and print keys: PT0021	Cable RS 232 [scale - computer]: PT0020
Tansponder card reader: CK-01	Cable [scale - Ethernet]: P0198
Barcode scanner	Large LCD display WWG-2 (digit height 4,5")
"PW-WIN" computer software	"RAD-KEY" computer software