

Table scales WPT/F



release date 12-02-2010

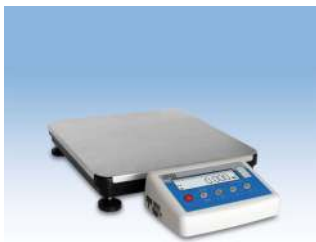

Table scales series WPT/F are designed for fast and precise mass determination. Taring in the whole measuring range enables determining of net mass of weighed loads.

WPT/F scales feature low-profiled esthetic construction and an indicator series PUE C/31 which is equipped with backlit, LCD display. Standard equipment of WPT/F scales includes a single RS 232 interface, internal rechargeable NiMH accumulators, and a power adapter. Scales series /F are offered with indicator installed on a pillar, connected through a cable or fixed to the scale construction.

Table scales series WPT/F can cooperate with PC software SCALE EDITOR, which displays the essential data on weighing process indicated on scale's display. It also enables editing and modifying all the user parameters from the PC computer level.

Optionally, the scales offer the possibility of weighing loads outside the weighing platform (so called under hook weighing). It is an alternative, for the loads with non-standard dimensions, shapes or emitting electromagnetic field. Extra equipment comprises additional display. It is used for controlling mass of the weighed load by a third party.

- Counting pieces
- Checkweighing
- Summing function
- Animal weighing
- Percent setup
- Peak hold
- Measurement in Newton

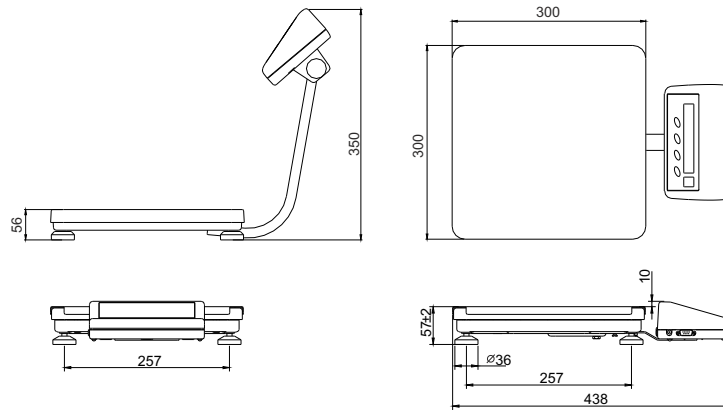

Technical data:

	WPT/F 3C	WPT/F 3/6C	WPT/F 6C	WPT/F 6/15C	WPT/F 15C	WPT/F 15/30C	WPT/F 30C
	WPT/F 3C/K	WPT/F 3/6C/K	WPT/F 6C/K	WPT/F 6/15C/K	WPT/F 15C/K	WPT/F 15/30C/K	WPT/F 30C/K
	WPT/F 3C/R	WPT/F 3/6C/R	WPT/F 6C/R	WPT/F 6/15C/R	WPT/F 15C/R	WPT/F 15/30C/R	WPT/F 30C/R
Max capacity	3 kg	3/6 kg	6 kg	6/15 kg	15 kg	15/30 kg	30 kg
Readability	1 g	1/2 g	2 g	2/5 g	5 g	5/10 g	10 g
Tare range	-3 kg	-6 kg	-6 kg	-15 kg	-15 kg	-30 kg	-30 kg
Pan size	300 × 300 mm						
Working temperature	-10° - +40 °C						
Output signal	RS 232						
Power supply	230V / 11V AC or 120V / 11V AC and 6 × AA NiMH accumulator						
Operation time on batteries	35 hours (average)						
Display	LCD (backlit)						
Net weight / Gross weight	5,5/ 6,5 kg						
Packaging dimensions	410×380×210 kg						

Additional equipment:

TABLE FOR SCALE	EXTERNAL POWER OUTPUT AP-2-1 (PLASTIC HOUSING)
"KAFKA" THERMAL PRINTER	RS 232/RS 485 CONVERTER KR-01
IMPACT PRINTER "EPSON"	RS 232/ETHERNET CONVERTER KR-04-1 (PLASTIC HOUSING)
ANTI-DUST CASE FOR EPSON PRINTER	RS 232 CABLE: SCALE-THERMAL PRINTER: P0136
COMPUTER SOFTWARE 'PW-WIN' AND 'RAD-KEY'	RS 232 CABLE: SCALE-COMPUTER: P0108
LCD ADDITIONAL DISPLAY WD-4/1	RS 232 CABLE: SCALE: EPSON PRINTER: P0151
LARGE SIZE ADDITIONAL DISPLAY WWG-2	CABLE FOR POWERING SCALE FROM CAR LIGHTER: K0047

RADWAG

26-600 Radom • Bracka Street 28 • POLAND • Phone: +48 48 3848800 • Fax: +48 48 3850010 • www.radwag.com • e-mail:export@radwag.com