

# PUE C41H MEASURING INDICATORS



release date 15-12-2008



## Basic functions of indicator series PUE C41H:

- Measuring units: [g], [kg], [N], [ct], [lb], [oz];
- Automatic dosing: single and dual threshold;
- Creation of mixtures according to set formulation;
- Tarring in whole measuring range;
- Automatic tare, tare memory, manual insertion of tare mass;
- +/- control with reference to standard mass;
- Percent deviation with reference to standard mass;
- Averaging of weighing result, digital filter;
- Control of Power Supply from batteries; Backlit adjustment while supplying from battery; Timer switch off;
- Adjustable speed of transmission in range between 1200-115200bit/s;
- Continuous transmission of data by RS 232;
- Manual or automatic mode for RS 232; Weighing loads with switched off autozero function;
- Measurement of maximal force influencing the weighing platform;
- Measurement of force influencing the weighing platform in Newtons;
- Control of starting mass;
- Possibility of connecting additional LCD display;
- Summing of weighing.
- Modular construction (depending on needs, electronic set can be extender by additional modules installed inside the indicator casing): analog modules (AN 0-10V, AN 4-20mA, AN 0-20mA), additional relay modules (PK 1), additional A/C relay module (DP 1), in/out module(WE 8, WE 4), RS 485 module (RS 1D) and Ethernet module (ET 1G, ET 1D).

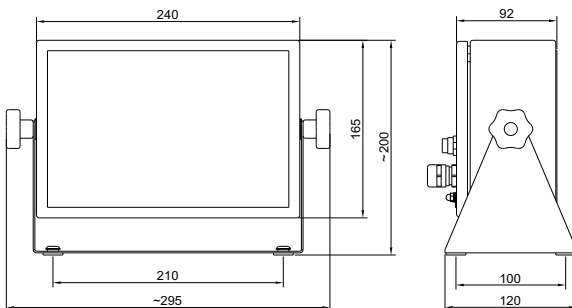

## Technical data:

### PUE C41H

Display type	LCD	
Casing	stainless steel	
Keyboard type	membrane	
Power Supply	85-265V AC 50/60 Hz, battery 6V 3Ah – operation time up to 9 h (buffer power supply)	
Data base size of the indicator	total memory size for data base: 4 MB	
Maximal quantity of divisions from converter	8 388 608	
OIML class	III	
Quantity of verifying units	6 000	
Maximal increase of signal	19mV	
Maximal voltage on 1 verifying unit	3,3 μV	
Minimal voltage on 1 verifying unit	1μV	
Minimal impedance of load cell	90 Ω	
Maximal impedance of load cell	1200 Ω	
Power voltage of load cell	5V	
Connection of load cells	4 or 6 cables + screen	
Working temperature	-10°C ÷ +40°C	
IP rating	IP 66/67	
Optoinsulated interfaces	RS 232 & RS 485	- (standard)
Inputs / outputs	3 optoinsulated inputs, 3 optoinsulated outputs;	- (standard)
	possibility of installing external PRINT and TARA buttons	- (option)
	4 optoinsulated inputs, 4 optoinsulated outputs	- (option)
Input / output module	8 reed relay outputs, 8 reed relay inputs	- (option)
Ethernet module	compatible with standard 10/100Mbit/s	- (option)
Analog output module	operation mode – 4-20mA, 0-20mA, 0-10V	- (option)
Relay module	4 relays with short circuiting switch	- (option)
Additional weighing platform module	metrological parameters as in main platform	- (option)

**RADWAG**

26-600 Radom • Bracka Street 28 • POLAND • Phone: +48 48 3848800 • Fax: +48 48 3850010 • www.radwag.com • e-mail:export@radwag.com