

PRECISION BALANCES PS/Y











release date 11-07-2011



Precision balances series PS/Y are the response for the growing market demands concerning simple operation and maximum automation of the weighing process.

Measurement reliability and accuracy is assured by internal automatic adjustment / calibration system triggered by time flow or temperature conditions.

Balances feature a new electronic module and are operated using a touch panel covering a 5.7" colour graphic display. Y scales have implemented new easily operated software.

-  Parts counting
-  Filling
-  Animal weighing
-  Density determination
-  Checkweighing
-  Percent setup
-  Statistics
-  Formulation

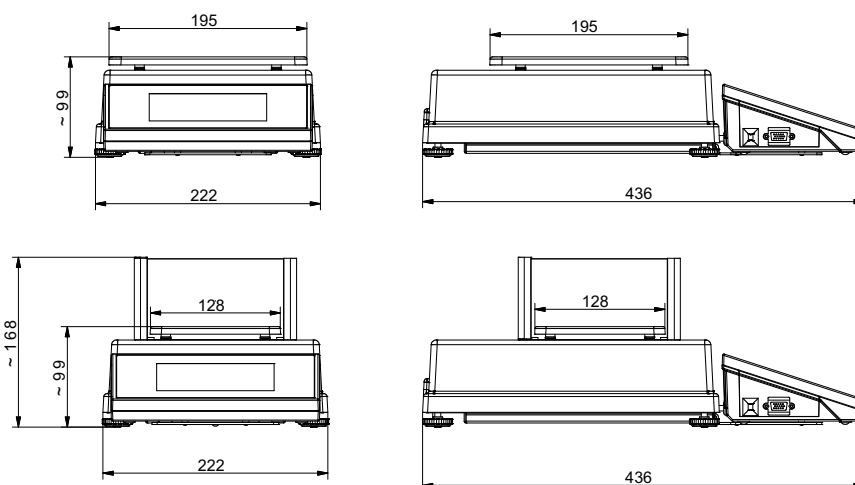

Technical data:

	PS 200/2000/Y*	PS 250/Y*	PS 450/Y*	PS 600/Y*	PS 750/Y	PS 1000/Y	PS 1500/Y*	PS 2500/Y*	PS 4500/Y*	PS 6000/Y*	PS 8000/Y**
Max capacity	200/2000 g	250 g	450 g	600 g	750 g	1000 g	1500 g	2500 g	4500 g	6000 g	8000 g
Minimal load	20 mg	20 mg	20 mg	20 mg	20 mg	20 mg	500 mg	500 mg	500 mg	500 mg	500 mg
Readability	1/10 mg	1 mg	1 mg	1 mg	1 mg	1 mg	10 mg	10 mg	10 mg	10 mg	10 mg
Tare range	-2000 g	-250 g	-450 g	-600 g	-750 g	-1000 g	-1500 g	-2500 g	-4500 g	-6000 g	-8000 g
Linearity	±2/10 mg	±2 mg	±2 mg	±3 mg	±3 mg	±3 mg	±20 mg	±20 mg	±20 mg	±30 mg	15 mg
Repeatability	1/10 mg	1 mg	1 mg	1,5 mg	1,5 mg	1,5 mg	10 mg	10 mg	10 mg	15 mg	±20 mg
Pan size	128×128 mm						195×195 mm				
Stabilization time	2 s / 1,5 s	2 s	2 s	2 s	2 s	2 s	1,5 s	1,5 s	1,5 s	1,5 s	1,5 s
Sensitivity drift	2 ppm/°C in temperature +15 - +35 °C										
Working temperature	+10 - +40 °C										
Power supply	110 ÷ 230 V AC / 50 ÷ 60 Hz / 13,5 ÷ 16 V DC / 1,1 A										
Interface	2xUSB, RS 232, Ethernet, 2inputs / 2 outputs (digital)										
Packaging size	570×325×225 mm										
Display	5,7" touch panel										

*verified balance, ** external calibration

Additional equipment:

Anti vibration table for laboratory balances	Mass standard
Printer Kafka, Epson, Citizen	LCD display WD-3/01/Y
Foot button for tare or print functions	Power adapter with battery and charger ZR-02
Density determination kit for solids and liquids	Power loop output AP2-1 (plastic version)
PC keyboard	Antistatic cable
Anti draft shield	Computer software: PW-WIN, RAD-KEY
Bar code scanner	Cable: P0136, P0151, P0108

RADWAG

26-600 Radom • Bracka Street 28 • POLAND • Phone: +48 48 3848800 • Fax: +48 48 3850010 • www.radwag.com • e-mail: export@radwag.com