

# WATERPROOF PLATFORM SCALES





release date 30-04-2010



Waterproof platform scales are designed to operate in humid conditions and direct contact with water.

They feature LCD display, stainless steel weighing pan. All scale components are made of stainless steel OH18N9. The indicator series PUE C/31H is installed on a pillar with possibility of changing the angle (optionally, the head can be installed on a 3 meter-long cable with possibility of hanging it on a wall). Range of capacities for these scales vary from 3 kg/1 g to 300 kg/100 g.

WPT/H scales are powered from mains, RS 232 as standard. On special request, waterproof platform scales can be manufactured with upgraded antirust coating.

-  Counting pieces
-  Checkweighing
-  Summing function



Waterproof scales feature 100 % waterproof protection of the load cell. Such design protects the load cells against the influence of ambient factors.

## Technical data:

	WPT 6H2	WPT 15H2	WPT 15H3	WPT 30H3	WPT 60H3	WPT 150H3
	WPT 6H2/K	WPT 15H2/K	WPT 15H3/K	WPT 30H3/K	WPT 60H3/K	WPT 150H3/K
Max capacity	6 kg	15 kg	15 kg	30 kg	60 kg	150 kg
Readability	2 g	5 g	5 g	10 g	20 g	50 g
Tare range	-6 kg	-15 kg	-15 kg	-30 kg	-60 kg	-150 kg
Pan size	250×300 mm		410×410 mm			
Working temperature	-10° - +40 °C					
Output signal	RS 232					
IP rating	IP 67 - construction, IP 66/67 - indicator					
Power supply	230V AC, 50Hz / 11V AC and internal accumulator					
Operation time on accumulators	~45 h					
Display	LCD (backlite)					
Net weight/Gross weight	9/10,3 kg		15,5/17,3 kg			
Packaging dimensions	580×320×360 mm		670×510×330 mm			

## Technical data:

	WPT 60H4	WPT150H4	WPT 60H5	WPT 150H5	WPT 300H5	WPT 150H6	WPT 300H6
	WPT 60H4/K	WPT150H4/K	WPT 60H5/K	WPT 150H5/K	WPT 300H5/K	WPT 150H6/K	WPT 300H6/K
Max capacity	60 kg	150 kg	60 kg	150 kg	300 kg	150 kg	300 kg
Readability	20 g	50 g	20 g	50 g	100 g	50 g	100 g
Tare range	-60 kg	-150 kg	-60 kg	-150 kg	-300 kg	-150 kg	-300 kg
Pan size	500×500 mm		600×600 mm		800×800 mm		
Working temperature	-10° - +40 °C						
Output signal	RS 232						
IP rating	IP 67 - construction, IP 66/67 - indicator						
Power supply	230V AC, 50Hz / 11V AC and internal accumulator						
Operation time on accumulators	~45 h						
Display	LCD (backlite)						
Net weight/Gross weight	23,5/25,8 kg		29,5/31,8 kg		42,5/45,8 kg		
Packaging dimensions	840×600×400 mm		840×700×400 mm		1160×820×340 mm		

### Technical data:

	WPT 3/6H2	WPT 6/15H2	WPT 6/15H3	WPT 15/30H3	WPT 30/60H3	WPT 60/150H3
	WPT 3/6H2/K	WPT 6/15H2/K	WPT 6/15H3/K	WPT 15/30H3/K	WPT 30/60H3/K	WPT 60/150H3/K
Max capacity	3/6 kg	6/15 kg	6/15 kg	15/30 kg	30/60 kg	60/150 kg
Readability	1/2 g	2/5 g	2/5 g	5/10 g	10/20 g	20/50 g
Tare range	-6 kg	-15 kg	-15 kg	-30 kg	-60 kg	-150 kg
Pan size	250×300 mm		410×410 mm			
Working temperature	-10° - +40 °C					
Output signal	RS 232					
IP rating	IP 67 - construction, IP 66/67 - indicator					
Power supply	230V AC, 50Hz / 11V AC and internal accumulator					
Operation time on accumulators	~45 h					
Display	LCD (backlite)					
Net weight/Gross weight	9/10,3 kg			15,5/17,3 kg		
Packaging dimensions	580×320×360 mm			670×510×330 mm		

### Technical data:

	WPT 30/60H4	WPT 60/150H4	WPT 30/60H5	WPT 60/150H5	WPT 150/300H5	WPT 150/300H6
	WPT 30/60H4/K	WPT 60/150H4/K	WPT 30/60H5/K	WPT 60/150H5/K	WPT 150/300H5/K	WPT 150/300H6/K
Max capacity	30/60 kg	60/150 kg	30/60 kg	60/150 kg	150/300 kg	150/300 kg
Readability	10/20 g	20/50 g	10/20 g	20/50 g	50/100 g	50/100 g
Tare range	-60 kg	-150 kg	-60 kg	-150 kg	-300 kg	-300 kg
Pan size	500×500 mm		600×600 mm			800×800 mm
Working temperature	-10° - +40 °C					
Output signal	RS 232					
IP rating	IP 67 - construction, IP 66/67 - indicator					
Power supply	230V AC, 50Hz / 11V AC and internal accumulator					
Operation time on accumulators	~45 h					
Display	LCD (backlite)					
Net weight/Gross weight	23,5/25,8 kg		29,5/31,8 kg			42,5/45,8 kg
Packaging dimensions	840×600×400 mm		840×700×400 mm			1160×820×340 mm

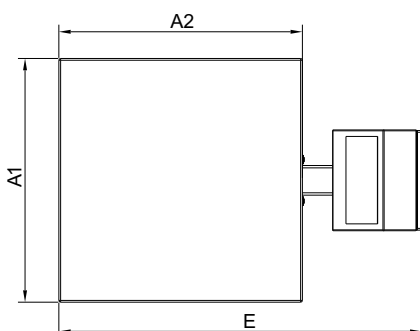
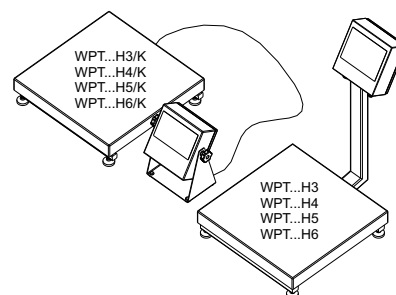
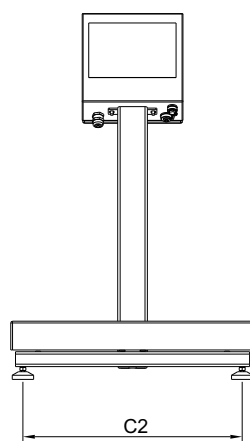
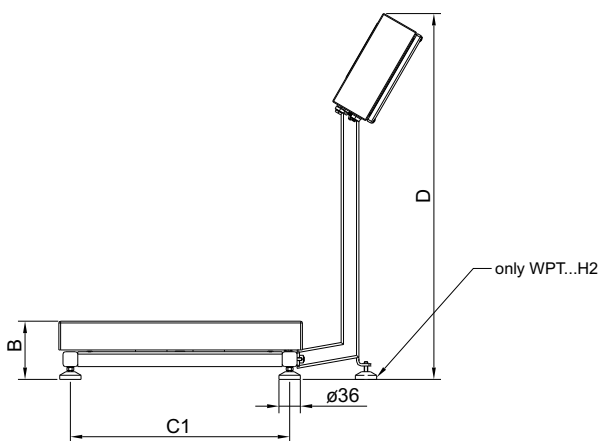

	A1	A2	B	C1	C2	D	E
WPT...H2	246	306	103 ± 3	268	208	~535	~485
WPT...H2/K	246	306	103 ± 3	268	208	-	-
WPT...H3	411	411	98 ± 2	370	370	~617	~613
WPT...H3/K	411	411	98 ± 2	370	370	-	-
WPT...H4	500	500	155 ± 5	400	400	~790	~718
WPT...H4/K	500	500	155 ± 5	400	400	-	-
WPT...H5	600	600	155 ± 5	500	500	~790	~818
WPT...H5/K	600	600	155 ± 5	500	500	-	-
WPT...H6	800	800	135 ± 5	740	720	~1100	~1050
WPT...H6/K	800	800	135 ± 5	740	720	-	-



Platform scale 150×200 mm with indicator installed on a pillar.  
 WPT 3 H1 M V1 - version 1 standard - aluminum load cell in 100 % waterproof construction, pillar height 24 cm;  
 WPT 3 H1 M V2 - version 2 - aluminum load cell in 100 % waterproof construction, pillar height 7 cm  
 WPT 3 H1 M V3 - version 3 - stainless steel load cell, pillar height 24 cm  
 WPT 3 H1 M V4 - version 4 - stainless steel load cell, pillar height 7 cm

WPT3H1 scales are also available with indicator installed on a cable. Max capacity of WPT 3H1 scale is 3kg/1g. Scales are powered from mains, RS 232 as standard. On special request, series WPT 3H1 is accessible in upgraded anti-corrosion steel.

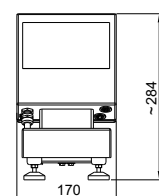
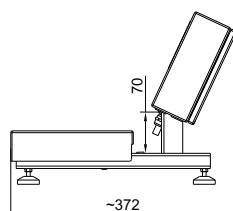
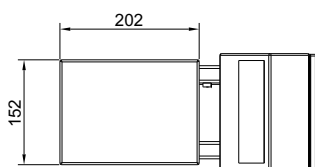
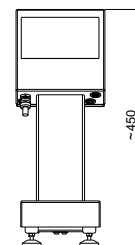
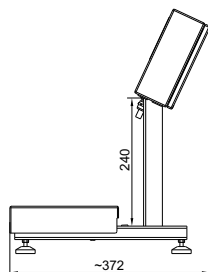

### Technical data:

	WPT 1,5/3H1	WPT 3H1
	WPT 1,5/3H1/K	WPT 3H1/K
Max capacity	1,5/3 kg	3 kg
Readability	0,5/1 g	1 g
Tare range	-3 kg	-3 kg
Pan size	200×150 mm	
Working temperature	-10° - +40 °C	
Output signal	RS 232	
IP rating	IP 67 - construction, IP 66/67 - indicator	
Power supply	230V AC, 50Hz / 11V AC and internal accumulator	
Operation time on accumulators	~45 h	
Display	LCD (backlite)	
Net weight/Gross weight	7/8,3 kg	
Packaging dimensions	520×260×290 mm	

### Additional equipment:

Kafka thermal printer	Anti-vibration table
Epson impact printer	Table for scale
Anti-dust case for Epson printer	RAD-KEY computer software
Stand for the indicator	PW-WIN computer software
Rs232 / Ethernet converter KR-04	LS-FS computer software
External power output	RS 232 cable: scale - thermal printer: P0253
LCD display WWG-2 (digit height 4,5")	RS 232 cable: scale - "Epson" printer: P0261
Conveyors: roller and other	Cable for plugging to car lighter 12V: K0042
	LCD display in stainless steel casing

### RADWAG

26-600 Radom • Bracka Street 28 • POLAND • Phone: +48 48 3848800 • Fax: +48 48 3850010 • www.radwag.com • e-mail:export@radwag.com