

OVERHEAD TRACK SCALES



release date 30-12-2010



Overhead track scales series WPT/2K are designed for weighing half carcass and porkhalf which are transported on scale's tracks. The weighing process starts when a roller with measured load enters a measuring section of the track. The load cells are installed lengthwise to the weighing track which is fixed with spherical mandrels. Such design eliminates tensions in the construction.

Scale can cooperate with carcass grading equipment.

Overhead track scales are manufactured either in galvanized and in stainless steel version, as dual range weighing instruments. They are equipped with stainless steel backlit LCD measuring indicator PUE C/31H.

- Counting pieces
- Checkweighing
- Summing function

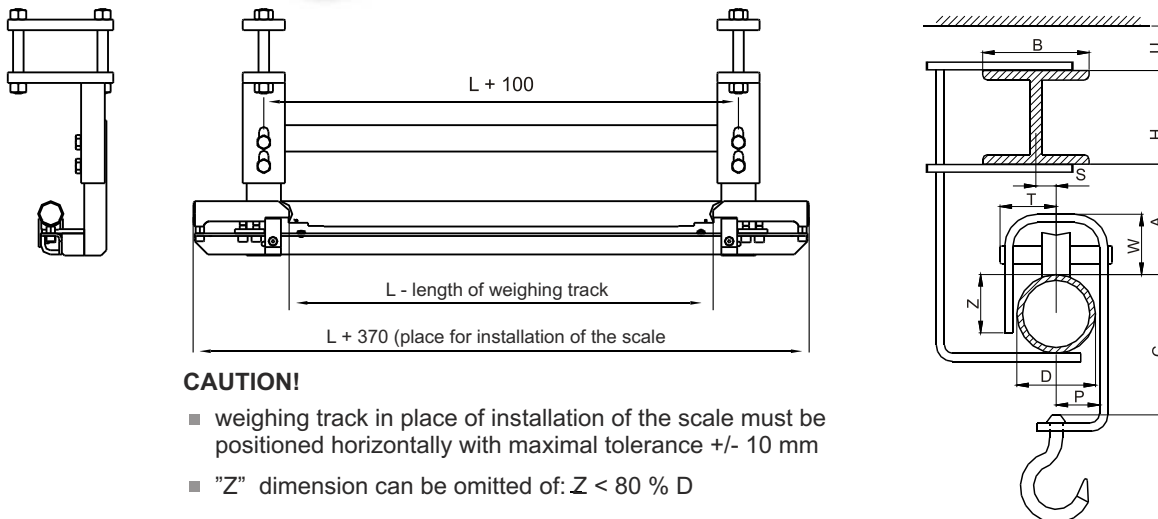

Technical data:

	WPT/2K 300/600	WPT/2K 300/600H
Max capacity	300/600 kg	300/600 kg
Readability	0,1/0,2 kg	0,1/0,2 kg
Tare range	-600 kg	-600 kg
Scale construction	galvanized	stainless steel
Track length	max. 800 mm	
Working temperature	-10° - +40 °C	
Output signal	RS 232	
Power supply	230V / 11V AC or 120V / 11V AC and internal accumulator	
Display	LCD (backlit)	

Additional equipment:

RACK FOR HEAD	IMPACT "EPSON" PRINTER
LCD DISPLAY	COMPUTER SOFTWARE: PW-WIN 2005, RAD-KEY 2000
LARGE SIZE LCD DISPLAY	EXTERNAL POWER OUTPUT AP-2
"KAFKA" THERMAL PRINTER	RS 232/RS 485 CONVERTER KR-01

RADWAG

26-600 Radom • Bracka Street 28 • POLAND • Phone: +48 48 3848800 • Fax: +48 48 3850010 • www.radwag.com • e-mail: export@radwag.com