

DENSITY DETERMINATION KIT

release date 15-07-2008



The density determination kit of solids and liquids is intended to cooperate with laboratory balances featuring weighing pans with dimensions $\varnothing 85$ and $\varnothing 100$ mm [KIT85] and weighing pan 128×128 mm [KIT 128].

Determining the density of solids and liquids is an inseparable part of laboratory work. Traditional method of density determination requires the operator to carry out multiple measurements and complex calculation. In result the operator ends with a density determination result which can be saddled with calculation and systematic errors. Additionally the amount of time dedicated to density calculation is relatively large.

Application of RADWAG balances featuring the density determination mode, it is possible to considerably simplify and speed up the whole process. Time amount required to obtain density result is very short, as all the process calculations are automatically carried out by a balance, and operator's activities are limited to:

- operation of balance's keyboard,
- placing the samples on the density kit weighing pans,
- hanging the plunger.

Density determination is enabled through application of the density kit for solids and liquids. It is an additional equipment of RADWAG laboratory balances. Balance software enabling density determination features:

- simplicity of use (all activities are described on balance's display),
- reliability (all calculation is automatically conducted by balance's software),
- fast data processing (result is obtained on determination of sample mass in water or plunger mass in liquid),
- accurate data processing (before every mass measurement, display indication is automatically zeroed, thus ensuring reliable and actual density determination result).

Specification:

- | |
|--|
| 1-beaker base |
| 2-pans suspension |
| 3-plunger |
| 4-beaker |
| 5-thermometer holder |
| 6-thermometer |
| 7-plunger string |
| 8-hook |
| 9-upper pan of the density determination kit for solids |
| 10-pan string |
| 11-lower pan of the density determination kit for solids |
| 12-additional weight |
| 13-additional stand for set of pans or plunger |

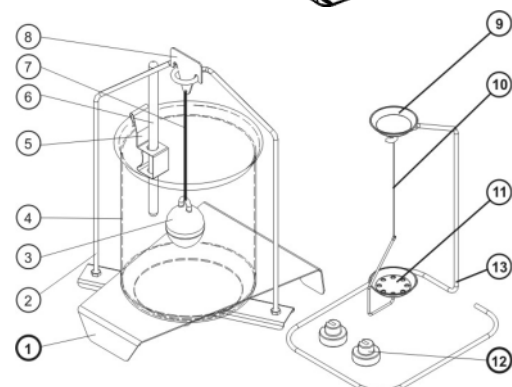
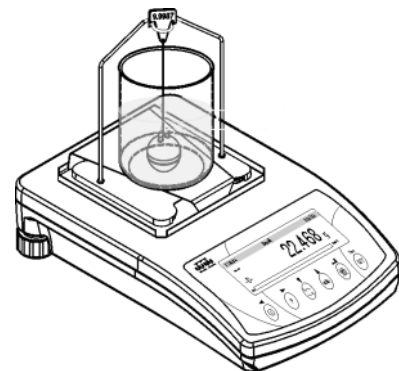

RADWAG

26-600 Radom • Bracka Street 28 • POLAND • Phone: +48 48 3848800 • Fax: +48 48 3850010 • www.radwag.com • e-mail: export@radwag.com