

# MYA 3Y MICROBALANCES



release date 06-03-2015



## 3Y SERIES MICROBALANCES - THE NOVELTIES

- ✓ Higher resolution – up to 600 million intervals
- ✓ More precise temperature measurement
- ✓ Brand new signal filtering algorithm, enabling selective tuning to actual interfering frequency.
- ✓ Modernized mechanics design - Susceptibility to air drafts reduced six times
- ✓ Cooperation with THB module
- ✓ Brand new, faster terminal comprising: audio module (audio readout of the weighing result), video module (tutorial videos playback), WiFi interface and possibility of cooperation with applications based on ANDROID system.

**New generation** of microbalances MYA 3Y are intended to measure mass with the highest accuracy. They feature 5,7" LCD colour touch panel which provides new possibilities of balance operation and presenting measurement results. Measurement reliability and accuracy are maintained by system of automatic internal adjustment / calibration.

Level control in the MYA 3Y series is based on LevelSENSING system, RADWAG patented solution, which uses a system of an electronic level. New function is online monitoring of ambient conditions through built-in ambient conditions module with visualization on balance's display. Personalization of balance settings is carried out in extended user profiles and multilevel system of access levels to balance's menu.

Control over opening and closing of the weighing chamber's door is carried out through programmable IR proximity sensors, installed on the terminal's overlay.

Differential weighing mode aids mass control of the same sample subjected to differed processes over time. It is particularly useful in pharmacy, environmental protection, petroleum chemistry, etc. Pipettes calibration mode is carried out using an adapter, which is an ergonomic tool aiding calibration and checking of piston pipettes using gravimetric measuring method. Extended databases enable storing all carried out measurements, with option of printing and exporting them. Standard and user defined printouts allow for maintaining documentation complying with GLP/GMP requirements practically in any application.

- Parts counting
- Dosing
- Checkweighing
- Formulation
- Percent deviations
- Statistics
- Animal weighing
- Differential weighing
- Pipettes calibration
- Statistical Quality Control
- Autotest (GLP, Filter)
- Automatic sliding door
- Air buoyancy compensation
- GLP procedures
- Infrared sensors
- Ambient conditions monitoring
- Newton unit measurement
- Replaceable units
- Moveable range \*

\* - only for MYA 0,8/3.3Y and MYA 11/52.3Y balances

## Dimensions:

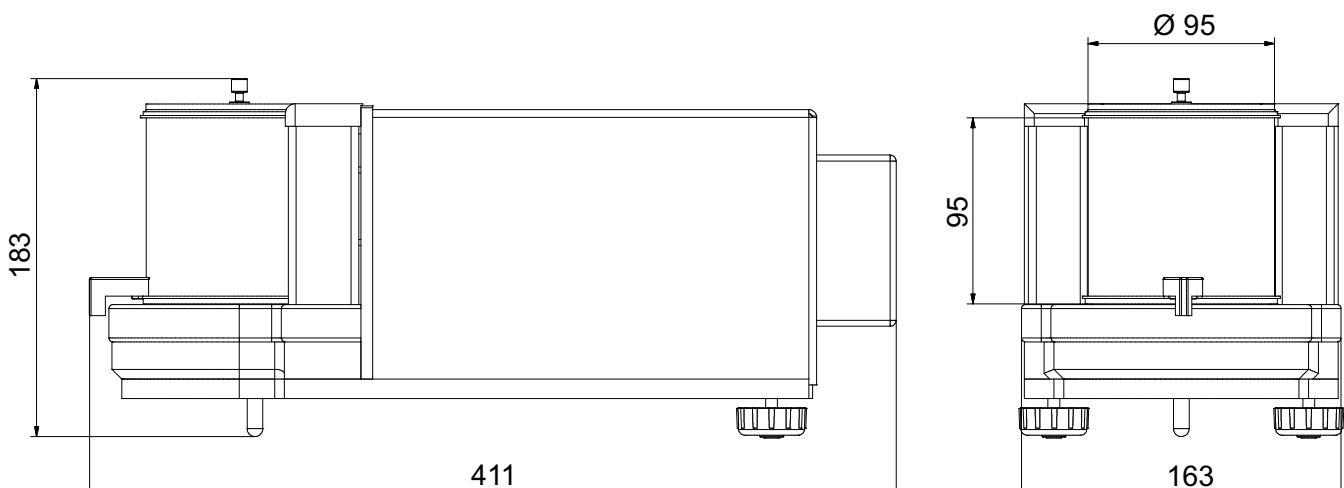

## Dimensions:

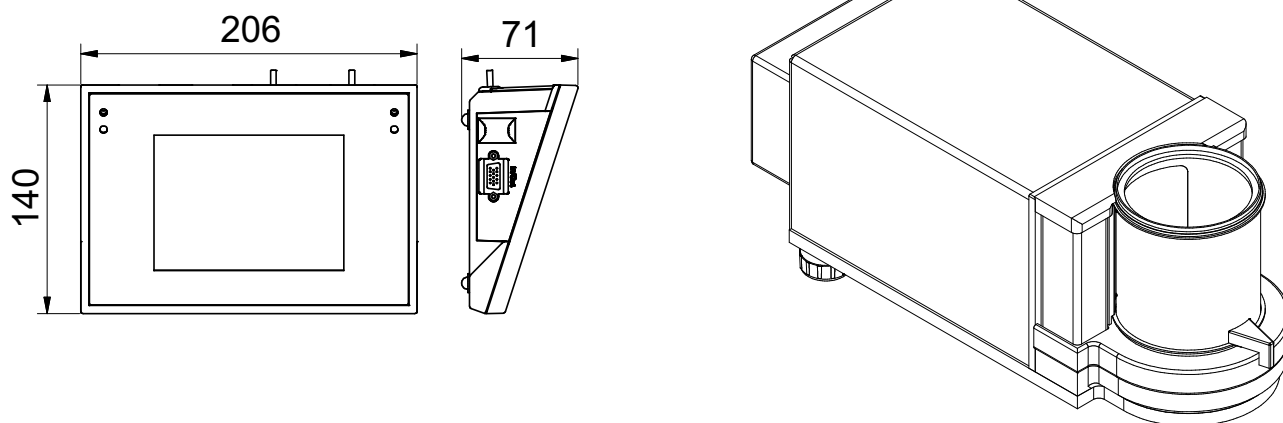

## Technical specification:

	MYA 2.3Y	MYA 0,8/3.3Y	MYA 5.3Y	MYA 11.3Y	MYA 21.3Y
Max load	-	-	-	-	-
Max load	2 g	0,8 g / 3 g	5 g	11 g	21 g
Readability	1 µg	1 µg / 10 µg	1 µg	1 µg	1 µg
Repeatability *	1 µg	1 µg (Rt ≤ 0,8g) 4,1 µg (0,8g < Rt ≤ 3g)	1 µg (Rt ≤ 2g) 1,6 µg (2g < Rt ≤ 5,1g)	1,5 µg (Rt ≤ 0,2g) 2,0 µg (0,2g < Rt ≤ 5g) 2,5 µg (5g < Rt ≤ 11g)	1,5 µg (Rt ≤ 0,2g) 2,0 µg (0,2g < Rt ≤ 5g) 2,5 µg (5g < Rt ≤ 11g) 3,0 µg (11g < Rt ≤ 21g)
Linearity	±3 µg	±3 µg / ±10 µg	±5 µg	±6 µg	±7 µg
Eccentric load deviation	3 µg	3 µg / 4 µg	5 µg	6 µg	7 µg
Sensitivity offset	$1,5 \times 10^{-6} \times Rt$	$1,5 \times 10^{-6} \times Rt$	$1,5 \times 10^{-6} \times Rt$	$3 \times 10^{-6} \times Rt$	$4 \times 10^{-6} \times Rt$
Sensitivity temperature drift	$1 \times 10^{-6} / ^\circ\text{C} \times Rt$	$1 \times 10^{-6} / ^\circ\text{C} \times Rt$	$1 \times 10^{-6} / ^\circ\text{C} \times Rt$	$1 \times 10^{-6} / ^\circ\text{C} \times Rt$	$1 \times 10^{-6} / ^\circ\text{C} \times Rt$
Sensitivity stability	$1 \times 10^{-6} / \text{Year} \times Rt$	$1 \times 10^{-6} / \text{Year} \times Rt$	$1 \times 10^{-6} / \text{Year} \times Rt$	$1 \times 10^{-6} / \text{Year} \times Rt$	$1 \times 10^{-6} / \text{Year} \times Rt$
Minimum weight (USP)	2 mg	2 mg	2 mg	3,0 mg	3,0 mg
Minimum weight (U = 1%, k = 2)	0,2 mg	0,2 mg	0,2 mg	0,3 mg	0,3 mg
Pan size	ø 16 mm	ø16 + 60 mm (for filters)	ø 26 mm	ø 26 mm	ø 26 mm
Weighing chamber dimensions	ø 90 × 90 mm				
Stabilization time	5 s				
Adjustment/Calibration	automatic (internal)				
Power supply	13,5 ÷ 16 V DC / 2,1 A				
Casing of the terminal	ABS plastic				
Display	colour 5,7" (640x480) with a resistive touch screen				
Processor	2 × 1 GHz				
Memory	RAM: 256 MB DDR2, flash: 8 GB microSD				
Interface	2×USB host, 2×RS 232, Ethernet 10/100 Mbit, WiFi 802.11 b,g,n				
Audio module	YES (voice messages support)				
Video support	YES (videos and multimedia instructions)				
IN / OUT	4 in / 4 out (digital)				
<b>Ambient conditions</b>					
Working temperature	+10 ° ÷ +40 °C				
Change rate of working temperature	±0,3 °C/h (±1 °C/8h)				
Atmospheric humidity	40% ÷ 80%				
Change rate of atmospheric humidity	±1%/h (±4%/8h)				

Rt - net weight

\* Repeatability is expressed as a standard deviation from 10 weighing cycles.

Data given in tables are values determined in typical laboratory conditions. In the actual operation conditions the values of these parameters may differ from those listed above because of the impact of ambient conditions and/or balance settings.

## Technical specification:

### MYA 11/52.3Y

Max load	52 g
Readability	1 µg / 10 µg
Repeatability *	1,5 µg (Rt ≤ 0,2g) 3,0 µg (0,2g < Rt ≤ 11g) 10 µg (11g < Rt ≤ 52g)
Linearity	±10µg / ±30 µg
Eccentric load deviation	6 µg / 10 µg
Sensitivity offset	3 × 10 <sup>-6</sup> × Rt
Sensitivity temperature drift	1 × 10 <sup>-6</sup> / °C × Rt
Sensitivity stability	1 × 10 <sup>-6</sup> / Year × Rt
Minimum weight (USP)	3,0 mg
Minimum weight (U = 1%, k = 2)	0,3 mg
Pan size	∅ 26 mm / ∅ 40 mm
Weighing chamber dimensions	∅ 90 × 90 mm
Stabilization time	5 s
Adjustment/Calibration	automatic (internal)
Power supply	13,5 ÷ 16 V DC / 2,1 A
Casing of the terminal	ABS plastic
Display	colour 5,7"(640x480) with a resistive touch screen
Processor	2 × 1 GHz
Memory	RAM: 256 MB DDR2, flash: 8 GB microSD
Interface	2×USB host, 2×RS 232, Ethernet 10/100 Mbit, WiFi 802.11 b,g,n
Audio module	YES (voice messages support)
Video support	YES (videos and multimedia instructions)
IN / OUT	4 in / 4 out (digital)
<b>Ambient conditions</b>	
Working temperature	+10 ° ÷ +40 °C
Change rate of working temperature	±0,3 °C/h (±1 °C/8h)
Atmospheric humidity	40% ÷ 80%
Change rate of atmospheric humidity	±1%/h (±4%/8h)

Rt - net weight

\* Repeatability is expressed as a standard deviation from 10 weighing cycles.

Data given in tables are values determined in typical laboratory conditions. In the actual operation conditions the values of these parameters may differ from those listed above because of the impact of ambient conditions and/or balance settings.

## Additional equipment:

Antivibration table for microbalances	Antistatic ionizer DJ-03
Professional weighing table	THB 2 ambient conditions module
Impact Epson printer	Additional LCD display "WD-5"
Label printer Citizen	PC USB keyboard
Anti draft shield for microbalances	Power adapter with battery and charger ZR-02
Tare and Print foot button	Mass standard
PW-WIN computer software	Antistatic cable PA 1
RAD-KEY computer software	Bar code scanner
REC-FS computer software	Cable RS 232 (balance - Epson, Citizen printer) "P0151"